

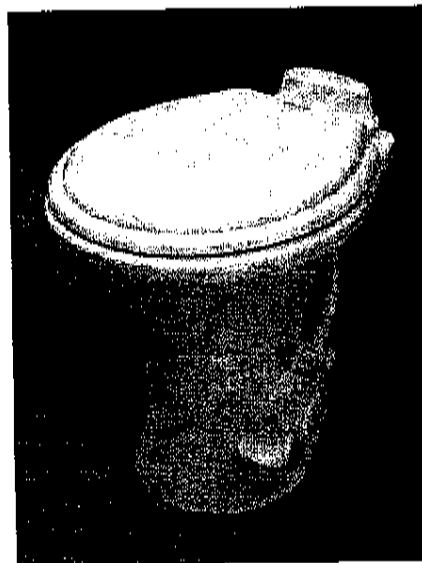

**EN** Gravity-flush toilet  
Instruction manual



## **310 and 320 Series Gravity-Flush Toilets**



**IF SERVICE OF THIS TOILET IS EVER REQUIRED,  
READ THIS BEFORE SERVICING PRODUCT.**

**DO NOT REMOVE TOILET FROM VEHICLE.  
DO NOT SEPARATE CERAMIC BOWL FROM PLASTIC BASE.  
DO NOT REMOVE FOOT PEDAL FROM BASE.  
DISASSEMBLY OF COMPONENTS MAY VOID WARRANTY.  
SEE MANUAL AND REPLACEMENT KITS FOR SERVICE INFORMATION.**

Dometic Corporation  
Sanitation Division

Call Customer Service: 1-800-321-9886 (8 a.m. – 5 p.m. ET)

**TOILET DOES NOT NEED TO BE REMOVED FROM VEHICLE FOR BASIC REPAIRS (if necessary)**

**Flush ball seal** – Dometic's revolutionary ball seal allows future replacement of worn or damaged ball seals without requiring tools or toilet disassembly. The ball seal can be changed in just a few minutes without removing the toilet from the floor. Detailed replacement instructions are included with replacement ball seal kits.

**Snap-in water valve cartridge** – Allows easy replacement of worn or damaged water valves. In cold climates, be sure to follow winterizing procedure in owner's manual to help avoid water valve failure. Refer to replacement instructions in new water valve kit prior to removal or installation of water valve assembly.

**Factory-sealed bowl-to-base assembly** – Unlike other Dometic foot-pedal toilets, **the bowl and base of 310 and 320 series toilets should not be separated for any reason.**

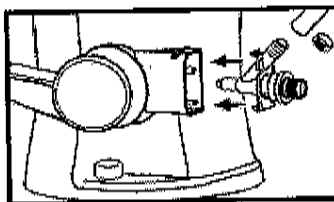
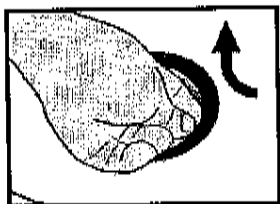

**Each Dometic toilet is 100% factory-tested to assure a watertight seal in the toilet bowl before it is shipped.**

After installation at the RV or other vehicle factory, the entire toilet and waste tank system is flood-tested for leaks by filling the system with water to the rim of the toilet bowl. This process requires holding the flush ball open with a device which may temporarily distort the ball seal from its original shape and, as a result, cause the seal to leak water into the waste tank during normal use. The ball seal may need to be reconditioned to its original shape.

**IF NEW TOILET DOES NOT HOLD WATER IN BOWL...**

Please follow the procedures below before attempting to replace the seal.

1. Hold flush ball in full open position by pressing on pedal.
2. Using finger, apply moderate downward pressure around edge of ball seal.
3. Close flush ball.
4. Keeping flush ball closed, pour one quart of hot tap water into toilet bowl.
5. Let water cool completely.
6. Check for leak.

If leak still persists, flush ball seal should be replaced. Follow instructions provided with replacement seal kit.

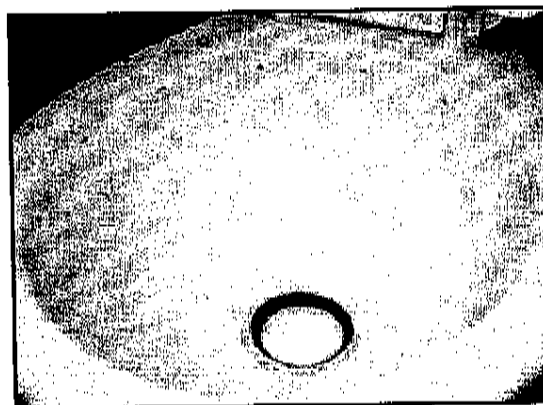

### Dometic Gravity-Flush Toilet

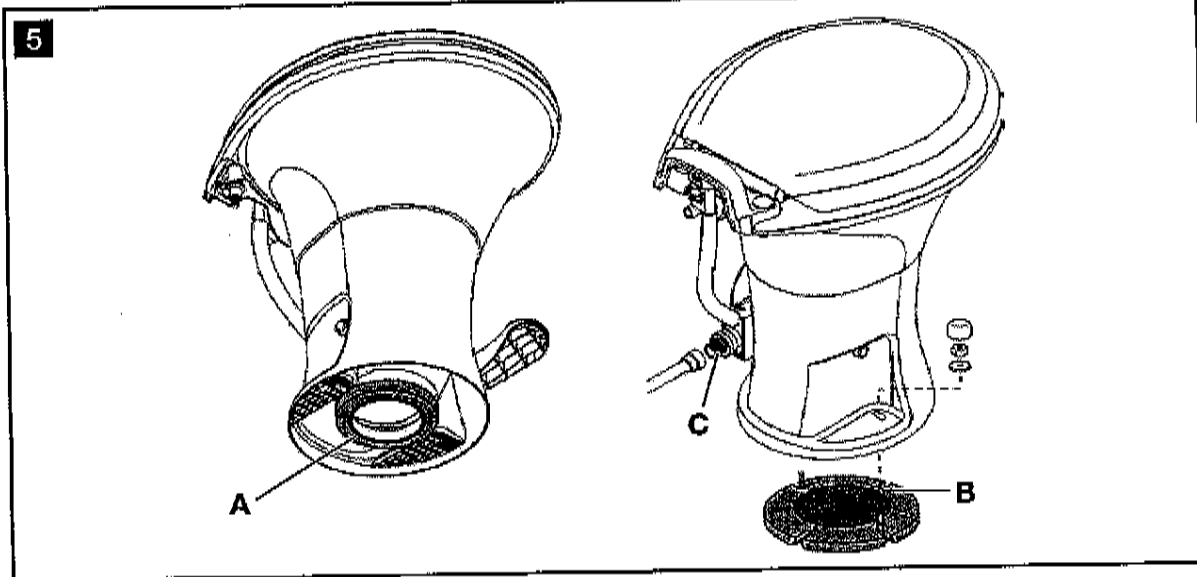
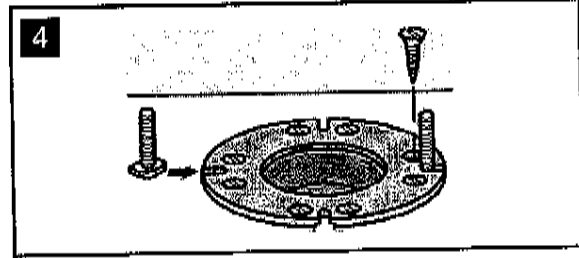
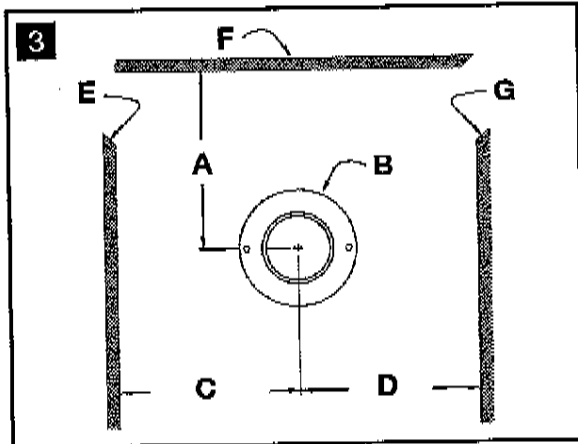
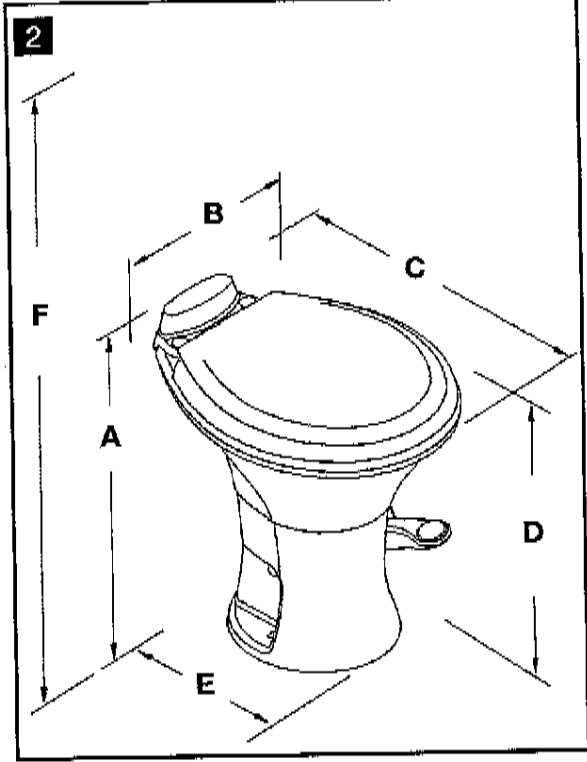
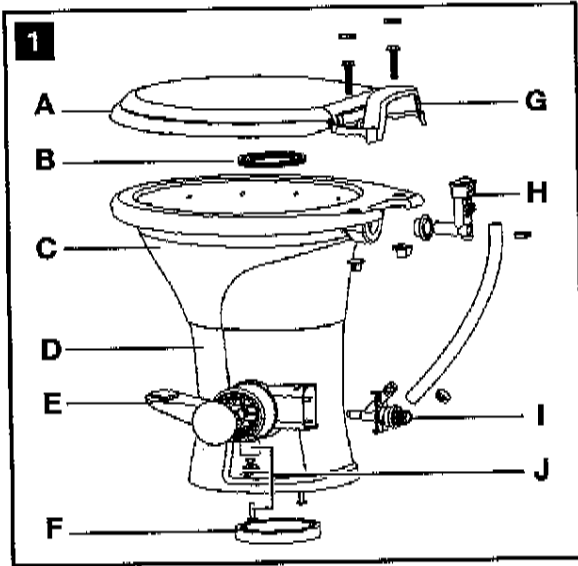

## Table of contents

1	Notes on using the manual .....	4
2	General safety instructions .....	4
3	Intended use .....	5
4	Specifications .....	5 - 6
5	Components .....	6
6	Installation .....	6 - 7
7	Operation .....	7
8	Cleaning .....	8
9	Winterization and storage .....	8 - 9
10	Troubleshooting .....	10
11	Warranty .....	11
12	Customer service .....	11

## 1 Notes on using the manual



### Caution!

Safety Instruction: Failure to observe this instruction can cause material damage and impair the function of the device.



### Note

Supplementary information for operating the device.

fig. **1** A, page 3 : This refers to an element in an illustration. In this example, item A in figure 1 on page 3.

## 2 General safety instructions

The manufacturer will not be held liable for claims for damage resulting from the following:

- Faulty installation or connection
- Damage to the unit from mechanical influences, misuse or abuse
- Alterations to the unit without express written permission from the manufacturer
- Use for purposes other than those described in this manual

### 2.1 Warnings

The following statements must be read and understood before installing, servicing and/or operating this product. Modification of this product may result in property damage.

1. Do not use chlorine or caustic chemicals, such as laundry bleach or drain-opening types, in the system. These products damage the seals in toilets and other plumbing valves.
2. Do not permit foreign objects (paper towels, paper cups, diapers, sanitary napkins, etc.) to be flushed through the toilet.
3. Mechanical seal toilets are designed to only discharge directly into a holding tank. Horizontal pipe runs as found in conventional residential or commercial plumbing systems cannot be accommodated.
4. Toilet bowl must be regularly cleaned and winterized according to "Cleaning" and "Winterization and storage" procedures on pages 8-9, or your warranty coverage may be voided.

## Dometic Gravity-Flush Toilet

## Intended use / Specifications

### 3 Intended use

Dometic 310 and 320 series toilets provide lightweight, residential-size toilets for installation directly above a holding tank.

#### 3.1 Benefits

**PowerFlush technology.** Improved pressurized rim flow creates high-speed, full bowl rinsing.

**Premium user comfort.** Full-size seat, deep bowl and 18-in. (457 mm) seat height result in greater homelike performance.

**Easy installation.** Two-bolt design fits most existing toilet floor flanges – great for new or replacement installations. Just place on floor flange, tighten bolts, connect water, and it's ready.

**Compact design.** Small footprint with 10-inch or 11-inch (254 or 279 mm) rough-in.

**Ergonomically enhanced pedal operation.** Lower pedal height for easier use; "one-direction" action to add water and flush.

### 4 Specifications

#### 4.1 Materials

##### Materials

Toilet bowl: vitreous ceramic

Model 310 toilet seat: polypropylene

Model 320 toilet seat: wood

Flush ball seal: nitrile butyl rubber

Base, foot pedal, water valve: polypropylene

Water valve: polypropylene

Vacuum breaker: ABS/polypropylene

Floor seal: nitrile rubber, foam

#### 4.2 Minimum installation requirements

Water Supply	Fitting	0.5 in. NPT
	Flow rate	3.0-5.0* gpm / 11.4-18.9 lpm recommended 2.0 gpm / 9.5 lpm minimum
	Static pressure	30-100 PSI / 206.8-689.5 kPa
Discharge	Floor flange	3 in./76 mm ID, 1/4-7/16 in. (6-11 mm) thick

\* Water supply that exceeds 5.0 gpm / 18.9 lpm may require a flow restrictor at toilet inlet. Specifications subject to change without notice.

#### 4.3 Toilet dimensions (fig. 2, page 3)

Ref.	Dimensions	
	Model 310	Model 320
A	20 in. / 508 mm	20 in. / 508 mm
B	15 in. / 381 mm	15 in. / 381 mm
C	19 in. / 483 mm	22 in. / 559 mm
D	18 in. / 457 mm - seat height	18 in. / 457 mm - seat height
E	14.75 in. / 375 mm	16 in. / 406 mm
F	33 in. / 838 mm - seat lid up	33 in. / 838 mm - seat lid up

## Specifications / Installation

## Dometic Gravity-Flush Toilet

### 4.4 Rough-in dimensions (fig. 3, page 3)

Ref.	Dimension/Description	
	Model 310	Model 320
A	10 in. / 254 mm	11 in. / 279 mm
B	Floor flange	
C	11 in. / 279 mm	11 in. / 279 mm
D	11 in. / 279 mm	11 in. / 279 mm
E	Left wall	
F	Back wall	
G	Right wall	

### 5 Components (fig. 1, page 3)

Ref.	Description
A	Toilet seat
B	Flush ball seal
C	Toilet bowl
D	Toilet base
E	Flush pedal
F	Floor flange seal

Ref.	Description
G	Vacuum breaker cover
H	Vacuum breaker
I	Water valve
J	Floor mounting hardware kit

Refer to complete parts list (available online at [www.dometic.com](http://www.dometic.com)) for additional information.

## 6 Installation



### Note

Be sure foot pedal, when pressed, touches same flat surface on which toilet is installed.



### Note

Be sure to follow recommended installation requirements in section 4.2 of this manual.

### 6.1 Tools required

- pliers or adjustable wrench
- 7/16-in. / 11 mm wrench

## Dometic Gravity-Flush Toilet

## Installation / Operation

### 6.2 Toilet Installation

1. To replace an older toilet, turn off water supply to toilet. Remove and drain water supply line. Remove toilet hold-down bolts/screws. Remove toilet from floor. Remove and discard old floor flange seal and hold-down bolts. Verify center of floor flange is at least 10 inches / 254 mm (for model 310) or 11 inches / 279 mm (for model 320) from back wall (fig. 3 A, page 3). Make sure top surface of floor flange is clean and free of any debris or sealant.
2. If installing a new floor flange, make certain that toilet mounting holes are located at the correct angle (fig. 3 B, page 3). Floor flange must be secured to floor with a minimum of four screws (8 is preferred). Insert two supplied T-bolts into slots in floor flange (fig. 4 , page 3).
3. Verify that floor flange seal is installed on base of toilet (fig. 5 A, page 3). Carefully set toilet over floor flange. Align holes in toilet base with T-bolts as toilet is lowered onto floor flange. Toilet must be aligned so that outlet of base fits inside of floor flange outlet hole.



#### Note

Entire toilet base does not rest completely on floor yet. Floor seal must be compressed in following steps.

4. Install floor mounting nuts and washers onto T-bolts. Carefully torque nuts to 30-40 inch-pounds. DO NOT OVERTIGHTEN. Alternate between sides when tightening to prevent distortion of base. When tight, base should be securely attached and flat against floor. Attach bolt covers onto nuts. (Fig. 5 B, page 3)
5. If toilet is being installed in a shower stall, apply a bead of caulk around base of toilet to prevent water seepage under base.
6. Connect water supply line and torque connection to 30-40 inch-pounds. DO NOT OVERTIGHTEN. (Fig. 5 C, page 3)
7. Turn on water supply line. Flush toilet several times and check for leaks.

## 7 Operation

### 7.1 Add water to bowl

To add water to the toilet, press the flush pedal part way down. Water flows into the bowl while flush ball remains closed. If the flush ball moves, let up on the pedal slightly. Adding water to an empty bowl helps prevent holding tank odors from entering the living space. Adding water is recommended prior to flushing solids and toilet paper.

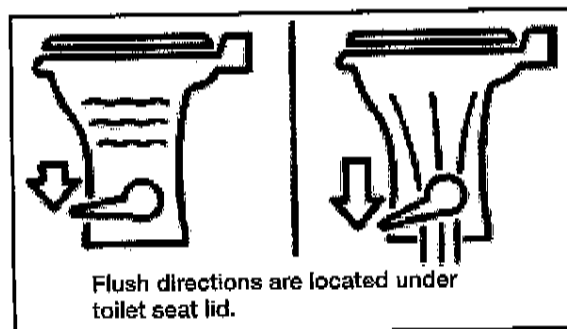

### 7.2 Flush toilet

To flush, press pedal down until it contacts the floor. Release pedal after complete flush.

- When flushing liquids, press the pedal for 1-2 seconds.
- When flushing solids, press pedal until contents are rinsed from bowl. Flushing longer than necessary will cause holding tank to fill too quickly.

A small amount of water will collect in the bowl after a flush to create an airtight seal.



#### Note

To prevent holding tank odors from entering the living space, make sure a small amount of water remains in the toilet bowl.

## 8 Cleaning

### 8.1 Routine toilet cleaning

For routine cleaning, use SeaLand® Toilet Bowl Cleaner. If you cannot find it in your area, contact Dometic for your nearest dealer. If the cleaner is not available, use most any non-abrasive bathroom and toilet bowl cleaner. Please follow label instructions.

### 8.2 Flush ball/seal cleaning

After a period of time, mineral deposits from hard water may build up on the flush ball or seal, resulting in a slow water leak. To prevent this, periodically clean the flush ball and seal.

1. Remove minor debris from the flush ball and seal by slowly pressing and releasing the flush pedal several times. This will loosen and rinse debris from the surfaces. Repeat several times for stubborn buildup.
2. If step 1 does not fully clean the ball and seal, clean with a soft bristle brush and SeaLand toilet bowl cleaner. Fully clean the top of the flush ball and under the seal where it contacts the flush ball. After cleaning underside of seal, apply light downward pressure to top of seal while brushing around full perimeter of seal.
3. If this does not correct a leaking seal, it may require replacement.

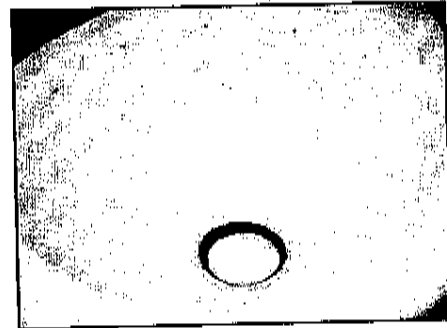

## 9 Winterization and storage

When a Dometic toilet is stored for long periods of time or may be exposed to temperatures below freezing, the toilet must be winterized or stored according to one of the following procedures.



#### Caution

This toilet is not intended for use when exposed to temperatures below freezing.



#### Caution

Never use automotive-type antifreeze (ethylene glycol) in freshwater systems.



#### Note

Use nontoxic antifreeze (propylene glycol) designated for potable water systems. (See vehicle owner's manual.)

### Storage options

#### Non-toxic Antifreeze Winterization (recommended method)

1. Pour antifreeze in potable water tank according to instructions from antifreeze manufacturer.
2. Flush toilet several times until antifreeze has flowed completely through toilet. For toilets with hand sprayer, the hand sprayer must be turned on to assure antifreeze is cycled through the sprayer.

#### Drain Water from Toilet

1. Turn off water supply to toilet.
2. Remove water supply line from water valve.
3. Place a small container under water valve inlet to catch draining water.

*(continued on next page)*



## Dometic Gravity-Flush Toilet

## Winterization and storage

4. Press flush pedal and allow water to completely drain from water valve and vacuum breaker.
5. Leave water line disconnected until threat of freezing temperature is past.



### Note

Never leave vehicle or premises unoccupied for extended periods of time with municipal water supply or onboard water pump turned on when there is a possibility of freezing temperature.

## IMPORTANT:

### Toilet warranty does not cover freeze-damaged water valve

The Dometic 310 and 320 series toilet warranty expressly excludes coverage for any damages to the toilet or vehicle that may occur as a result of improper winterization of the toilet. **An indicator of improper winterization is freeze damage to the water valve which results in leaks.**

Dometic 310 and 320 series toilet water valves exceed maximum water pressure as defined by North American plumbing code agencies. However, if trapped water freezes in piping that supplies water to the toilet, it expands and creates extremely high pressure that can damage the valve (see photo). To avoid this, winterize the toilet as described in this manual. If freeze-damage occurs as a result of improper winterization, replace the water valve with a 300/310/320 toilet water valve kit, part number 385311641. **IF WATER VALVE IS RETURNED FOR WARRANTY CLAIM, DOMETIC RESERVES THE RIGHT TO DENY CLAIM IF PROBLEM IS CAUSED BY FREEZE DAMAGE.**

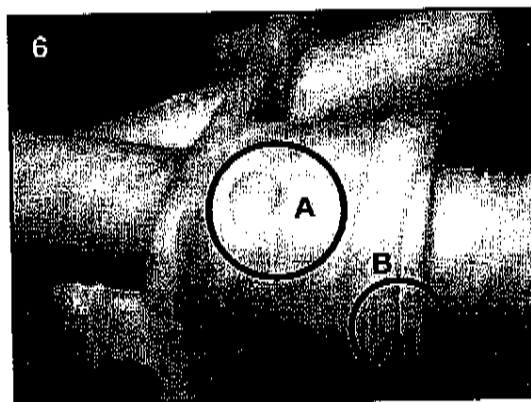

Fig. 6 A – Freeze Damage Indicator Window: white stress marks indicate freeze damage  
B – Water valve damage due to severe exposure to below-freezing temperature

## Troubleshooting

## Dometic Gravity-Flush Toilet

## 10 Troubleshooting

Problem	Possible Cause	Service Instruction
1. Water will not stay in bowl.	<ul style="list-style-type: none"> <li>a. Flush ball seal is not properly positioned.</li> <li>b. Flush ball or seal is dirty.</li> <li>c. Worn or damaged flush ball seal.</li> </ul>	<ul style="list-style-type: none"> <li>a. Press pedal to hold flush ball open, then lightly press down around edge of ball seal with finger to conform to flush ball.</li> <li>b. Clean flush ball and seal.</li> <li>c. Replace seal.</li> </ul>
2. Odor from toilet when flush ball is open.	<ul style="list-style-type: none"> <li>a. Plugged holding tank vent.</li> <li>b. Odor from holding tank contents.</li> </ul>	<ul style="list-style-type: none"> <li>a. Clear obstruction from vent.</li> <li>b. Add deodorant to holding tank.</li> </ul>
3. Odor from toilet when flush ball is closed.	<ul style="list-style-type: none"> <li>a. No water in bowl.</li> <li>b. Damaged flush ball seal.</li> <li>c. Damaged floor flange seal.</li> </ul>	<ul style="list-style-type: none"> <li>a. Add water to bowl.</li> <li>b. Replace seal.</li> <li>c. Replace floor seal.</li> </ul>
4. Flush ball will not close completely.	<ul style="list-style-type: none"> <li>a. Too much friction between flush ball and seal.</li> </ul>	<ul style="list-style-type: none"> <li>a. Clean and lubricate flush ball and seal with silicone spray or furniture polish.</li> </ul>
5. Water flow into toilet will not stop.	<ul style="list-style-type: none"> <li>a. Worn or defective water valve.</li> </ul>	<ul style="list-style-type: none"> <li>a. Replace water valve.</li> </ul>
6. Water does not enter toilet bowl properly.	<ul style="list-style-type: none"> <li>a. Insufficient water flow rate at toilet inlet.</li> <li>b. Screen at water valve inlet is clogged.</li> <li>c. Water valve is worn or damaged.</li> <li>d. Plugged rim wash holes in toilet.</li> </ul>	<ul style="list-style-type: none"> <li>a. Make sure flow rate at toilet inlet is 3.0-5.0 gpm / 11.4-18.9 lpm (recommended rate).</li> <li>b. Clean screen.</li> <li>c. Replace water valve.</li> <li>d. Clean rim wash holes.</li> </ul>
7. Hand sprayer leaks (hand sprayer is not provided with all models).	<ul style="list-style-type: none"> <li>a. Hand sprayer is defective.</li> </ul>	<ul style="list-style-type: none"> <li>a. Replace hand sprayer.</li> </ul>
8. Water is leaking from water valve.	<ul style="list-style-type: none"> <li>a. Water line connection is loose or not seated properly.</li> <li>b. Water valve is damaged or defective.</li> </ul>	<ul style="list-style-type: none"> <li>a. Insure that threads are not cross-threaded and tighten connection.</li> <li>b. Replace water valve.</li> </ul>
9. Water is leaking from toilet base.	<ul style="list-style-type: none"> <li>a. Toilet is not secure to floor.</li> <li>b. Worn or defective floor flange seal.</li> </ul>	<ul style="list-style-type: none"> <li>a. Tighten toilet mounting bolts.</li> <li>b. Replace floor flange seal.</li> </ul>
10. Water is leaking from rear of toilet.	<ul style="list-style-type: none"> <li>a. Loose vacuum breaker.</li> <li>b. Damaged or defective vacuum breaker.</li> <li>c. Cracked or defective toilet bowl.</li> </ul>	<ul style="list-style-type: none"> <li>a. Make sure vacuum breaker stem is pushed fully into sealing grommet in back of bowl.</li> <li>b. Replace vacuum breaker.</li> <li>c. Replace toilet.</li> </ul>

## Dometic Gravity-Flush Toilet

## Warranty / Customer service

### 11 Warranty

#### Manufacturer's Two-Year and Ten-Year Limited Warranty

Dometic Corporation warrants, to the original purchaser only, that this Dometic® gravity discharge toilet, if used for personal, family or household-like purposes, is free from defects in material and workmanship for a period of two (2) years from the date of purchase.

Dometic also warrants, to the original purchaser only, that the ceramic portion of the toilet bowl will not scratch or craze for a period of ten (10) years if used for personal, family or household-like purposes, and is regularly cleaned as described in the product owner's manual.

If this Dometic product is placed in commercial or business use, it will be warranted, to the original purchaser only, to be free of defects in material and workmanship for a period of ninety (90) days from the date of purchase.

Dometic reserves the right to replace or repair any part of this product that proves, upon inspection by Dometic, to be defective in material or workmanship. All labor and transportation costs or charges incidental to warranty service are to be borne by the purchaser-user.

#### EXCLUSIONS

IN NO EVENT SHALL DOMETIC BE LIABLE FOR INCIDENTAL OR CONSEQUENTIAL DAMAGES, FOR DAMAGES RESULTING FROM IMPROPER INSTALLATION, OR FOR DAMAGES CAUSED BY NEGLIGENCE, ABUSE, ALTERATION, OR USE OF UNAUTHORIZED COMPONENTS. THIS INCLUDES FAILURES WHICH MAY RESULT FROM NOT FOLLOWING THE WINTERIZATION OR CLEANING PROCEDURES AS DESCRIBED IN THIS OWNER'S MANUAL. ALL IMPLIED WARRANTIES, INCLUDING ANY IMPLIED WARRANTY OF MERCHANTABILITY OR FITNESS FOR ANY PARTICULAR PURPOSE, ARE LIMITED TO A PERIOD OF ONE (1) YEAR FROM DATE OF PURCHASE.

#### IMPLIED WARRANTIES

No person is authorized to change, add to, or create any warranty or obligation other than that set forth herein. Implied warranties, including those of merchantability and fitness for a particular purpose, are limited to one (1) year from the date of purchase for products used for personal, family or household-like purposes, and ninety (90) days from the date of purchase for products placed in commercial or business use.

#### OTHER RIGHTS

Some states do not allow limitations on the duration of an implied warranty, and some states do not allow exclusions or limitations regarding incidental or consequential damages; so, the above limitations may not apply to you. This warranty gives you specific legal rights, and you may have other rights which vary from state to state.

To obtain warranty service, first contact the local dealer from whom the product was purchased or go to <http://www.dometic.com/enus/Americas/USA/Customer-Support/> for a dealer near you.

### 12 Customer service

#### 12.1 Toilet model identification

The toilet model identification label is located on the toilet base under the water valve. Please have this information ready if contacting Dometic for customer service.

#### 12.2 Contact information

There is a strong, worldwide network to assist in servicing and maintaining your toilet system. For the Authorized Service Center near you, please call from 8:00 a.m. to 5:00 p.m. (ET) Monday through Friday.

You may also contact or have your local dealer contact the Parts Distributor nearest you for quick response to your replacement parts needs. They carry a complete inventory for the Dometic product line.

Telephone:	1 800-321-9886	U.S.A. and Canada
	330-496-3211	International
Fax:	330-496-3097	U.S.A. and Canada
	330-496-3220	International
Web site:	<a href="http://www.Dometic.com">http://www.Dometic.com</a>	

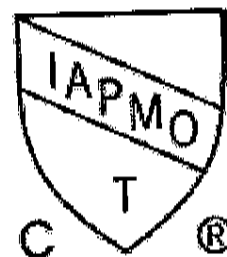
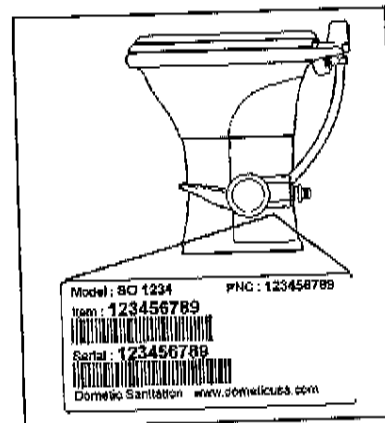

## Dometic Gravity-Flush Toilet

---

Dometic Group is a customer-driven, world-leading provider of leisure products for the RV, automotive, truck and marine markets. We supply the industry and aftermarket with a complete range of air conditioners, refrigerators, awnings, cookers, sanitation systems, lighting, mobile power equipment, comfort and safety solutions, windows, doors and other equipment that make life more comfortable away from home.

Dometic Group supplies a wide range of workshop equipment for service and maintenance of built-in air conditioners. Dometic Group also provides specially designed refrigerators for hotel rooms, offices, wine storage and transport and storage of medical products.

Our products are sold in almost 100 countries and are produced mainly in wholly-owned production facilities around the world.

 **Dometic®**

DOMETIC CORPORATION, SANITATION DIVISION  
13128 SR 226 | PO BOX 38  
BIG PRAIRIE, OHIO 44811 USA  
[www.Dometic.com](http://www.Dometic.com)